



Nottinghamshire  
County Council

# The Outdoor Equipment Store Minibus Booking Form

Booking Ref:

Before completing this form please read the terms and conditions overleaf.  
Please telephone to check availability of minibus.

School/Youth Organisation: ..... County Council cost code: .....

Address: .....

Name of Contact: ..... E-mail: .....

Tel: ..... Fax: .....

Period of Hire: (please indicate your requirements by ticking the appropriate boxes)

I wish to book:      12 seater Minibus       15 seater Minibus       17 seater Minibus       with towbar

Collection Date:..... approx. time:..... Return Date:..... approx. time:.....

**Drivers' Details:**

All drivers must hold a Nottinghamshire County Council or Nottingham City Council minibus permit which must be shown along with their driving licence upon collection of the minibus.

Drivers' Names	County/City Council Permit Number	Expiry Date

I am fully aware of the £250 excess damage claim against any one claim      Yes       No   
I agree to the hire terms and conditions.      Signed: ..... Date: .....

**For Office Use Only**

**Driver Details:**      Checked

**Mileage:** At start: ..... Finish:..... **Fuel:** At start:..... Finish:..... Charge:.....

**Condition of Minibus** (please note any internal or external damages):

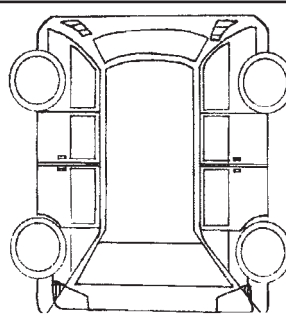
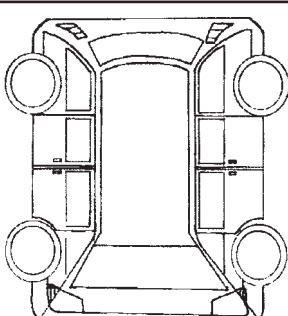
On Collection	Internal damage details	On Return	Internal damage details
			
Seat belts checked		Seat belts checked	

Hirer's acceptance after inspection      Signed: ..... Date: .....

Date of Return: ..... Received by: .....	Invoice details:.....
--	-----------------------

Charge details: ..... x day/weeks = £ ..... + excess £ ..... = Total £ .....

# Minibus Hire

## Terms and Conditions

1. Minibuses can only be hired to Nottinghamshire County Council and Nottingham City Council establishments. If groups are not listed in County or City Directories then they are required to provide evidence of affiliation, **otherwise hire will be refused.**
2. All drivers must produce their DVLA licence and current Council permit to drive upon collection otherwise the vehicle cannot be released.
3. Any damage occurring to the bus due to the hirer's negligence and not covered by Nottinghamshire County Council or Nottingham City Council insurance will be charged to the hirer. This includes cleaning charges.
4. Cancellation of booking less than 30 days before hire will result in the full hire rates being charged to the hirer if a replacement booking cannot be made.
5. Excess damage will be charged at £250 against any one insurance claim. Loss of any subsequent hire due to vehicle being off road will be charged to customer.
6. A strict non smoking policy exists within vehicles.
7. The hirer is fully responsible for any interior damage accidental or wilful, including upholstery damage and valeting. Tyre condition, windscreen, side screens, lighting clusters, mirrors, indeed any repair deemed above and beyond normal wear and tear is the hirers responsibility.
8. Whilst every effort is made to supply, as requested, a quality vehicle, Nottinghamshire County Council accept no responsibility whatsoever for the loss or curtailment due to vehicle failure or for any circumstances beyond the control of the Nottinghamshire County Council. The hirer must take adequate precautions in order to insure against all eventualities and outcomes.
9. Vehicles not returned at the agreed time will incur excess charges particularly if the follow on group are affected in any way.
10. Any groups who organise their own comprehensive insurance must provide copies of that policy at the time of booking, **otherwise hire will be refused.**

Please note there is a minimum booking charge of £10 on all bookings

**Our opening hours: 9.00am - 4.30pm Monday - Thursday  
9.00am - 4.00pm Friday**

**Services outside these hours can be made by prior arrangement.**



### Contacting us

email [outdoorequipment@nottsc.gov.uk](mailto:outdoorequipment@nottsc.gov.uk)

phone **01623 661328**

fax **01623 661549**

post **The Outdoor Equipment Store, Unit 1, Kings Mill Way  
Hermitage Industrial Estate, Mansfield,  
Nottinghamshire NG18 5ER**

internet [www.outdoorequipmentstores.co.uk](http://www.outdoorequipmentstores.co.uk)